

Duct Tape Phone Holster (Razor version) Assembly Overview

Back View

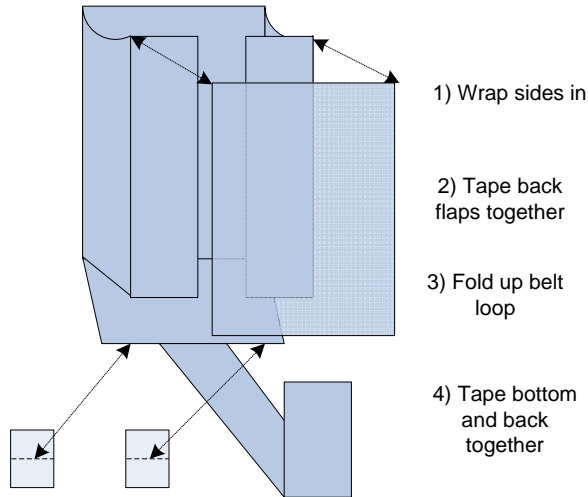

-Print this form at 100% scale for life-size pieces on the next page

-Exposed sticky surfaces are shown by color:

Sticky Side Up

Sticky Side Down

-Panels are made by taking two pieces of duct tape, and joining the sticky sides together.



-Pieces larger than 2" tall are made by overlapping 2 strips by 1/8". Then cut to the proper size.



Front View

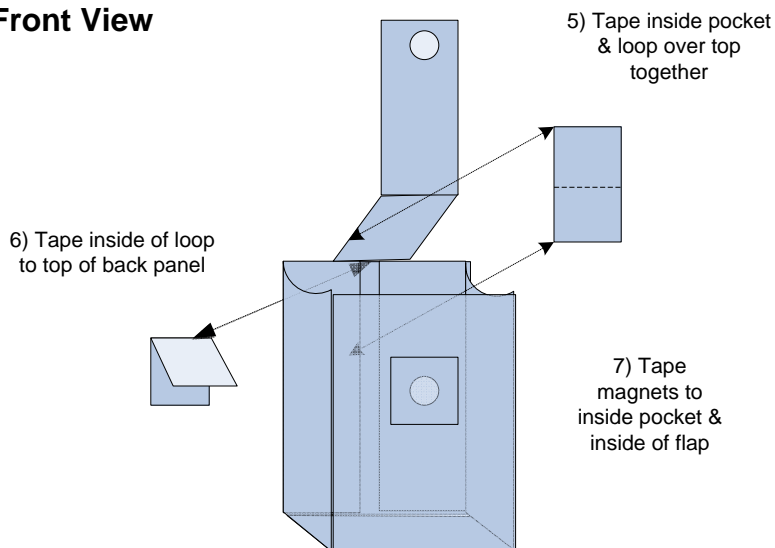

Assembly Tips:

-The holster is one piece that folds together, with small pieces to hold it together

-It's easiest to make this by building once large panel, then cutting the shape out with a knife or sharp scissors.

-Lines on template are for creasing only.

-Fold the template around your phone, then tape the back flaps together. Do the same when adjusting the magnets on the flap.

-The belt loop takes a lot of strain, thus it needs small pieces top & bottom to strengthen it.

-The magnets should be as flat as possible. I used old hard drive servo magnets. Also consider magnets from a broken holster.

-For smoother (and less sticky) edges, leave 1/8" on one side of the panel to roll over. Do this for the top edges of the pocket, and the flap. This same technique is used with my Duct Tape Wallet Template.

